

TEXA

ADAS CALIBRATION HEAVY DUTY TRUCKS

CCS 2 DYNAMICS - MOBILE CALIBRATION FRAME

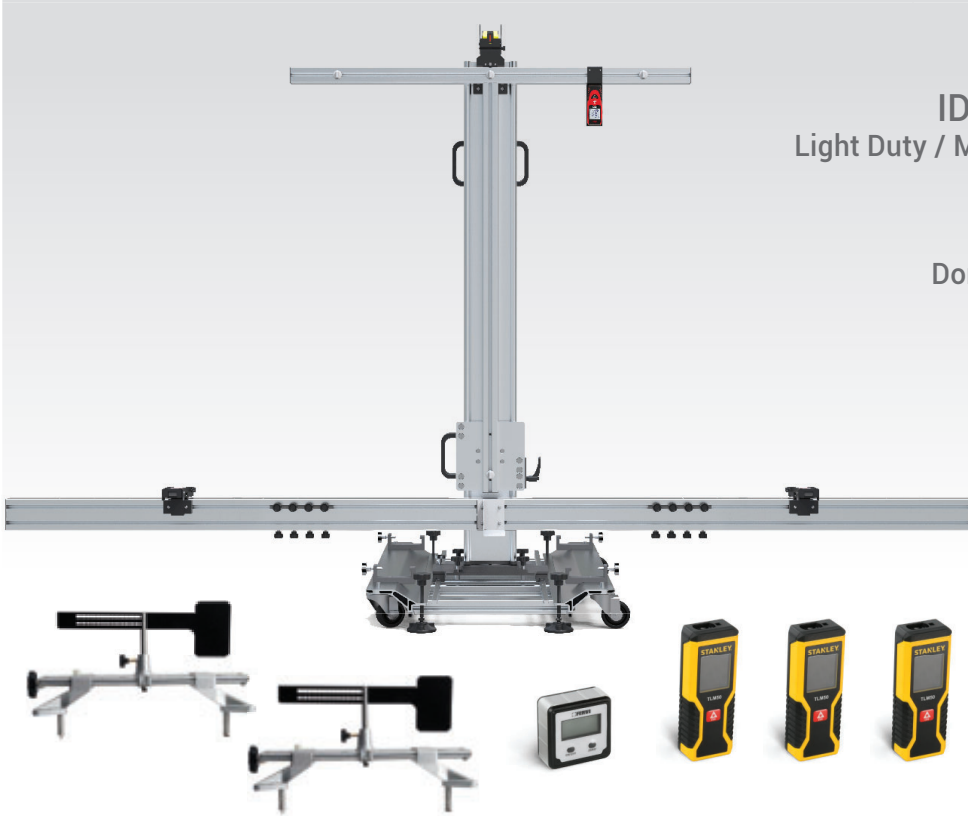

IDC5 TRUCK Coverage
Light Duty / Medium Duty / Heavy Duty



IDC5 CAR Coverage
Domestic / Asian / European



INCLUDED WITH PACKAGE:

- Bluetooth Distance Measures (3)
- Distance Measure Brackets (3)
- Digital Angle Gauge
- Self Centering Wheel Clamps
Set Of Two (From 12" to 28")
- Bendix Front Camera Target
- Calibration Frame & Assembly

BT LASER

DISTANCE MEASURE

ACCURATE CENTERING AND
SQUARING OF CALIBRATION
FRAME TO VEHICLE



VIRTUAL POSITIONING

GUIDED PROCEDURE

IDC5 SOFTWARE CONFIRMS STEP-BY-STEP
BLUETOOTH LASER DISTANCE MEASURE &
CALIBRATION FRAME MICRO ADJUSTMENTS



DIAG REPORT

CREATE AND SAVE

DIAGNOSTIC REPORT
CONFIRMING POSTSCAN
CALIBRATION ACCURACY

COMPATIBILITY

Designed to function with IDC5 installed on TEXA AXONE, or any Windows based laptop.



ACCURATE CALIBRATION

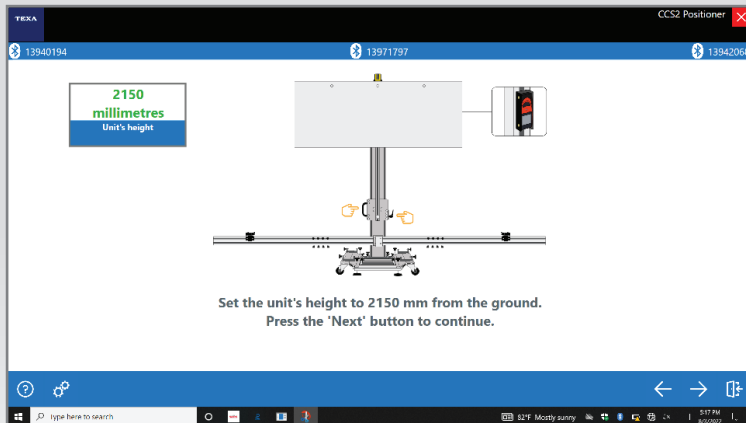

BLUETOOTH DIGITAL DISTANCE MEASURES

Transverse & Axial
Frame Adjustment
Fast & Easy Setup
Configuration Changes

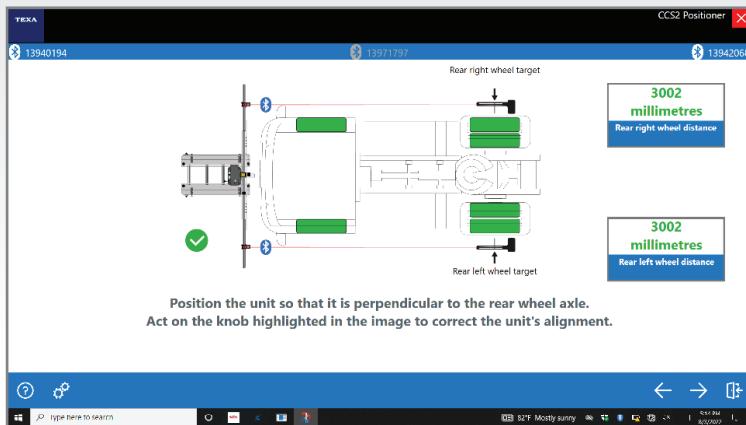

VIRTUAL POSITIONING GUIDED SOFTWARE

Digital Measurement
Confirms Precise
Centering & Squaring
Vehicle Placement

1:1 Proportion Ratios For ALL Targets
Meet OE Specifications For Every Manufacturer

PRE-SCAN / POST CALIBRATION REPORT

PDF FILE EASILY PRINTED OR SAVED TO SHOP SYSTEM FOR INSURANCE CARRIER SUBMISSION

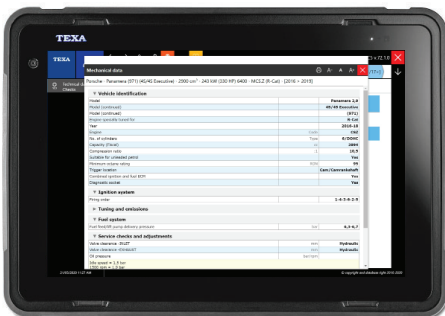

1 Confirm Vehicle System Data

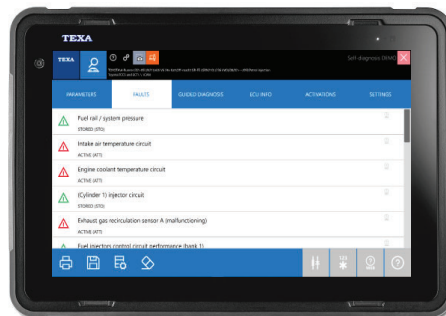

2 Global System Scan All DTCs

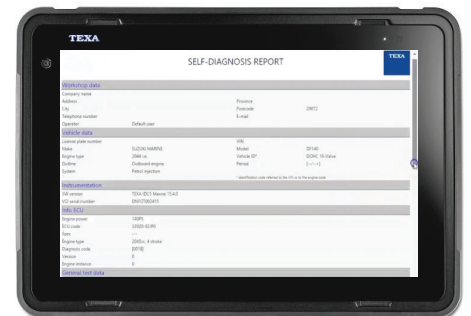

3 Create Vehicle System Report