

# IDC6

SOFTWARE

UPDATE

CAR 2025.03





# IDC6 CAR 2025.03

## Software update

Starting from the **IDC6** version, new terminology is introduced to describe the software versions, divided in two types of updates: **CORE** and **Environment**.



**1)** The **CORE** update is the evolution of the unified software architecture, shared by all the environments.

This architecture optimises access to the information and improves the efficiency in running the functions, guaranteeing faster response times and significantly reduced loading times.

The **CORE** update follows a progressive numbering that starts from **1** and reflects the developments and improvements made at an application level.

**2)** The **Environment** update is about the specific software version for each environment.

Its numbering is divided in two parts:

- The first number is the year in which the update is released (for example, **2025.x**);
- The second number is a progressive index that increases with each new update released during the year (for example, **2025.03**).

This new assignment allows clearly distinguishing between the architecture innovations (CORE) and the specific updates for the various environments.

The **IDC6 CAR 2025.03** software update is the latest evolution of the famous diagnostic software by **TEXA**.

It is the peak of innovation and integration in the field of automotive diagnostics, as it can interact and continuously adapt to the new features in the industry.

It creates the perfect synergy between **TEXA**'s display units and vehicle interfaces, taking repair professionals always to the core of multi-brand and multi-environment diagnostics.

Its advanced architecture and **an ever more intuitive diagnostic interface** provide an incredible diagnostic experience, also thanks to the introduction of **innovative diagnostic functions that exploit the potential of Artificial Intelligence (AI)**, which allow users a quick and precise access to the diagnostic information they need in order to solve any kind of problem in the vehicle.



Furthermore, **IDC6** updates itself constantly.

This allows being always at the forefront of modern vehicle diagnostics.

The system was designed to face the challenges of the future of diagnosis.

In fact, with the evolution of the technologies that feature the latest-generation mobility industry, the need for authentication in order to perform protected operations or settings provided for by the manufacturers becomes more and more common.

**IDC6** is an intelligent application as it has an evolutionary capability to satisfy user needs over time, by learning from their behaviours and recommending the use of certain functions that are used less.

**IDC6 CAR 2025.03** includes the **update of as many as 18 makes**. The work of TEXA's technical developers also led to further increasing the coverage of the **ADAS, electric and hybrid vehicles, interactive "DASHBOARD" screens** with over **790** new possible selections, and **wiring diagrams**.

**IDC6 CAR 2025.03** is characterised by over **1700 new possible selections** for the major makes on the market worldwide, among which:

**ABARTH, ACURA, ASTON MARTIN, AUDI, BENTLEY, BMW, BUICK, CADILLAC, CHEVROLET, CHRYSLER, DODGE, FERRARI, FORD, GENESIS, GMC, HONDA, HUMMER, HYUNDAI, INFINITI, JAGUAR, JEEP, KIA, LAND ROVER, LAMBORGHINI, LEXUS, LINCOLN, LOTUS, MASERATI, MAZDA, MCLAREN, MERCEDES-BENZ, MERCURY FORD, MG, MINI, MITSUBISHI, NISSAN, PLYMOUTH, POLESTAR, PORSCHE, RAM, ROLLS-ROYCE, SAAB, SATURN, SCION, SUBARU, TESLA, TOYOTA, VOLKSWAGEN, VOLVO.**

#### NOTICE FOR CUSTOMERS WHO OWN A Windows PC

Dear Customers, to make the most of all the functions in the **TEXA IDC6** diagnostic software, you need to update your Personal Computers to the latest version of the operating system Windows 10 or Windows 11.

#### OTHER NOTICES

Please note that the software updates are not available for unsupported tools.  
For more information, please contact your trusted TEXA dealer.



## New features included in the IDC6 CAR 2025.03 version





# CAR 2025.03

- DIAGNOSTIC DASHBOARDS AND TGS3 DASHBOARDS
- DIAGNOSIS

## DIAGNOSTIC DASHBOARDS AND TGS3 DASHBOARDS

New **TGS3 DASHBOARDS** have been added for **VOLVO** hybrid vehicles.

Below are a few example images:

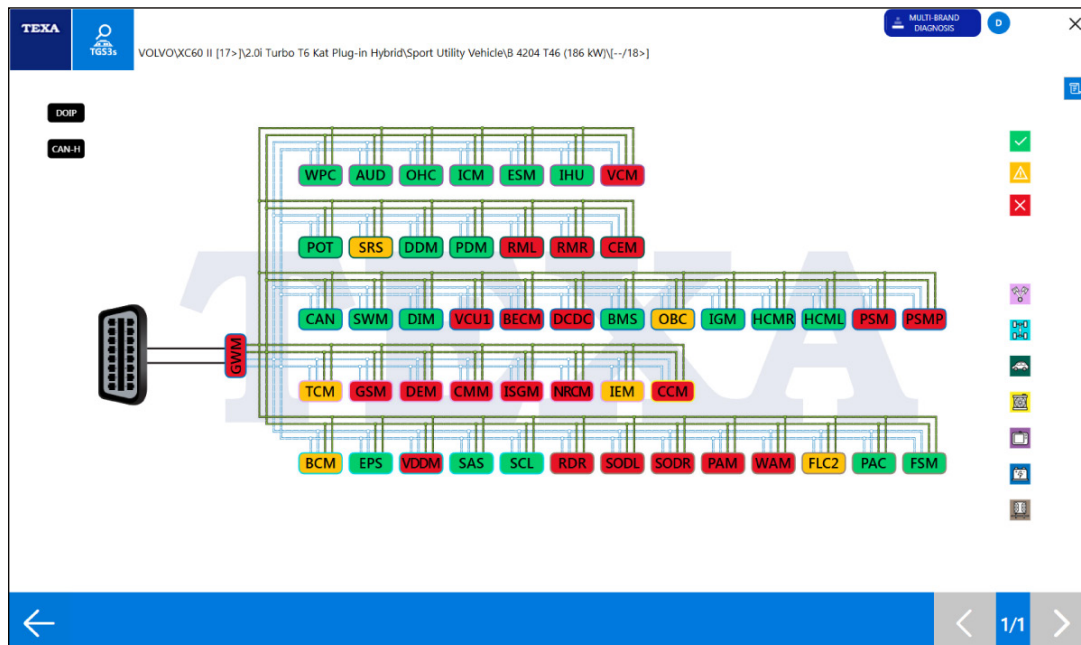

New **PARAMETER DASHBOARDS** for **VOLVO** hybrid vehicles.



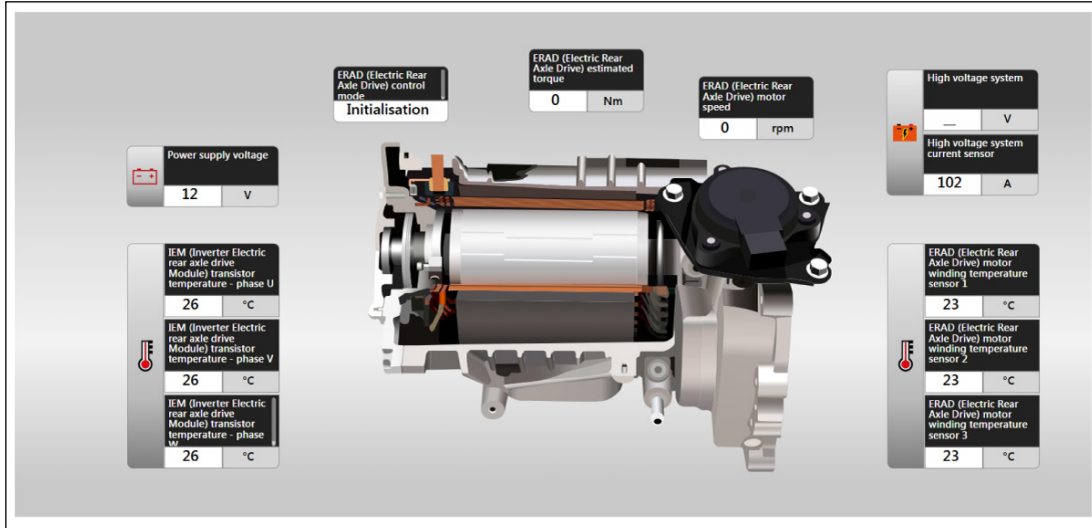

## DIAGNOSIS

In the "Latest version application list" section, users can find the updates related to the diagnostic coverage available in the IDC6 CAR 2025.03 software.

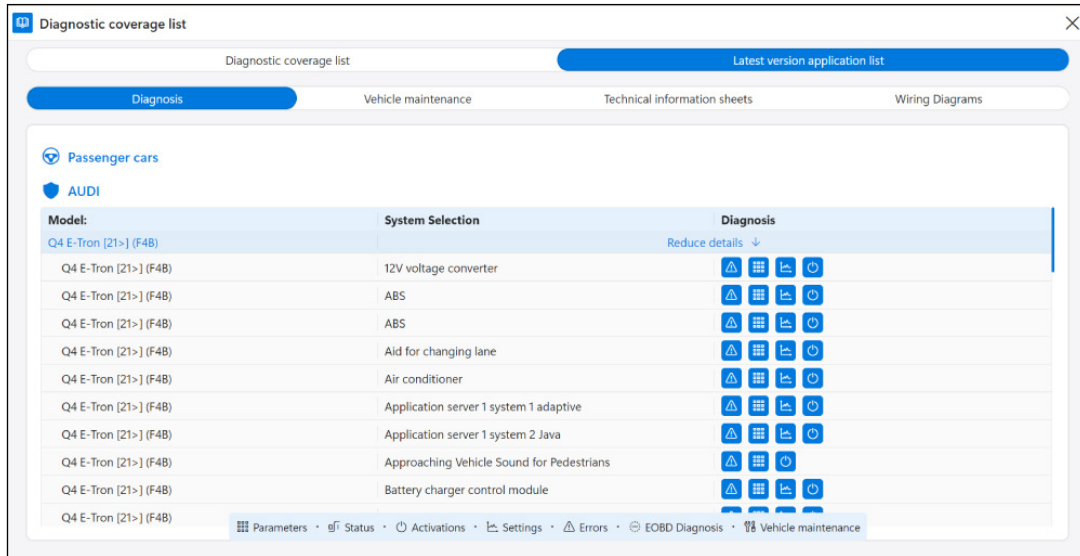

Example of new applications section in IDC6.

**NOTE:**

For further information see our website [www.texa.com](http://www.texa.com) in the DIAGNOSTIC COVERAGE section.



## AUDI

New diagnostic systems have been developed for the models:

- SQ6 E-Tron [24>] (GF) Sportback
- Q4 E-Tron [21>] (F4B)
- Q4 E-Tron [21>] (F4N) Sportback

## JEEP

New diagnostic systems have been developed for the model:

- Avenger [23>]

## MAZDA

New diagnostic systems have been developed for the models:

- CX-60 [22>] (KH)
- CX-70 [24>] (KK)
- CX-90 [23>] (KK)

## MERCEDES-BENZ

New diagnostic systems have been developed for the model:

- Sprinter III (906) M.Y. 2013

## VOLKSWAGEN

New diagnostic systems have been developed for the models:

- Golf VIII [24>] (CD1) Facelift
- Golf VIII [24>] (CG5) Variant Facelift

## SUPERCAR

### MASERATI

New diagnostic systems have been developed for the models:

- GranCabrio [24>] (M189)
- Grecale [22>] (M182)
- GranTurismo [23>] (M189)
- MC20 [20>] (M240)
- Grecale [22>] (M182)
- Ghibli [13>] (M157)
- Levante [16>] (M161)

Please note that this document is confidential. Total or partial copying without authorisation by TEXA S.p.A. is forbidden. Data, descriptions and illustrations may vary with respect to those shown here. TEXA S.p.A. reserves the right to make changes of any kind to its products, without prior notice.

